

Umschaltventile

– DFE 052/2 und DFE052/3 –



– Magnet –

Bestellnr.	Typ	Code
254-010-01000	DFE052/2A18ES-W201-12VDC	12A210009
254-010-01050	DFE052/2A18ES-W201-24VDC	12A210010
254-010-01100	DFE052/2B18ES-W201-12VDC	12A210014
254-010-01150	DFE052/2B18ES-W201-24VDC	12A210011
254-010-01200	DFE052/2B18ES-Y201-24VDC	12A210016
254-010-01250	DFE052/3A18ES-W201-12VDC	12A240020
254-010-01300	DFE052/3A18ES-W201-24VDC	12A240040
254-010-01350	DFE052/3A18ES-W201-24VDC-Viton	12A240016
254-010-01400	DFE052/3A18ES-Y201-12VDC	12A240021
254-010-01450	DFE052/3A18ES-Y201-24VDC	12A240041
254-010-01500	DFE052/3B18ES-W201-12VDC	12A240023
254-010-01550	DFE052/3B18ES-W201-24VDC	12A240044
254-010-01600	DFE052/3D18ES-W201-12VDC	12A240011

254-010

DFE

with solenoid control

Working conditions

This catalogue shows technical specifications and diagrams measured with mineral oil of 46 mm²/s - 46 cSt viscosity at 40°C temperature.

		DFE052	DFE10	DFE20
N. of available ways		2-3-6-8	3-6	3-6
Nominal flow rating	in steady conditions	60 l/min	90 l/min	140 l/min
Operating pressure (maximum)*	without drain	200 bar 2900 psi	200 bar 2900 psi	200 bar 2900 psi
	with drain	315 bar 4600 psi	315 bar 4600 psi	315 bar 4600 psi
Available nominal voltage	VDC	12-24 48-110	12-24-48	12-24
	VAC 50Hz (with C04 connector)	24-110-220	110-220	24-110-220
Potenza nominale	W	40	60	60
Internal leakage A(B)→T	Δp=100 bar 1450 psi with fluid and valve at 40°C	7 cm ³ /min 0.43 in ³ /min	10 cm ³ /min 0.61 in ³ /min	15 cm ³ /min 0.92 in ³ /min
Fluid		Mineral base oil		
Fluid temperature	with NBR seals	da -20° a 80°C		
	with FPM seals	da -20° a 100°C		
Viscosity	operating range	da 15 a 75 mm ² /s - from 15 to 75 cSt		
	minimum	12 mm ² /s - 12 cSt		
	maximum	400 mm ² /s - 400 cSt		
Max. level of contamination		19/16 - ISO 4406		
Ambient temperature		da -40° a 60°C		

NOTE - For different working conditions please contact Customer Service.

(*) - This value is reachable only in steady conditions; for dynamic working conditions see the pages from 49 to 52.

Standard threads

ALL PORTS	BSP (ISO 228/1)	UN-UNF (ISO 11926-1)
DFE052	G 3/8	3/4-16 UNF-2B (SAE 8)
DFE10	G 1/2	7/8-14 UNF-2B (SAE 10)
DFE20	G 3/4	1 1/16-12 UN-2B (SAE 12)
DRAIN PORT		
L	G 1/4	7/16-20 UNF-2B (SAE 4)

with solenoid control

DFE

Hydraulic circuit

2-way

Available as body only in DFE052/2 execution; for other executions 3-way body is used.

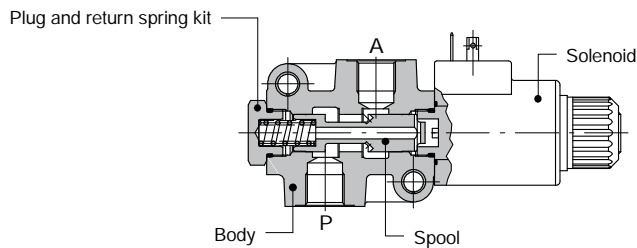

Spool type A

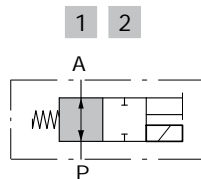

Spool type B

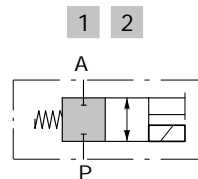

Performance data

Pressure drop versus flow
P→A

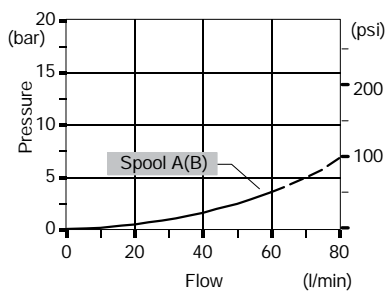

Minimum dynamic conditions
(supply = Vn - 10%, coil at 70 °C)

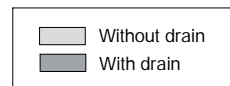
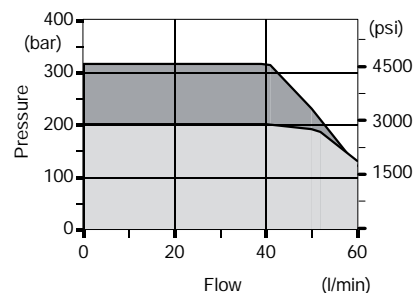

DFE

with solenoid control

Hydraulic circuit

3-way

It's possible to obtain 2-way diverter valve plugging port A or B.

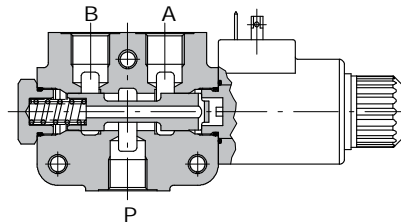

Spool type A

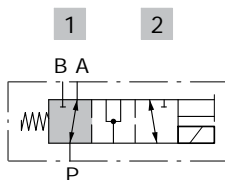

Spool type B

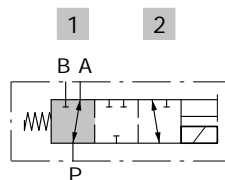

Spool type D

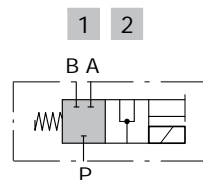

Performance data

Pressure drop versus flow: P→A(B)

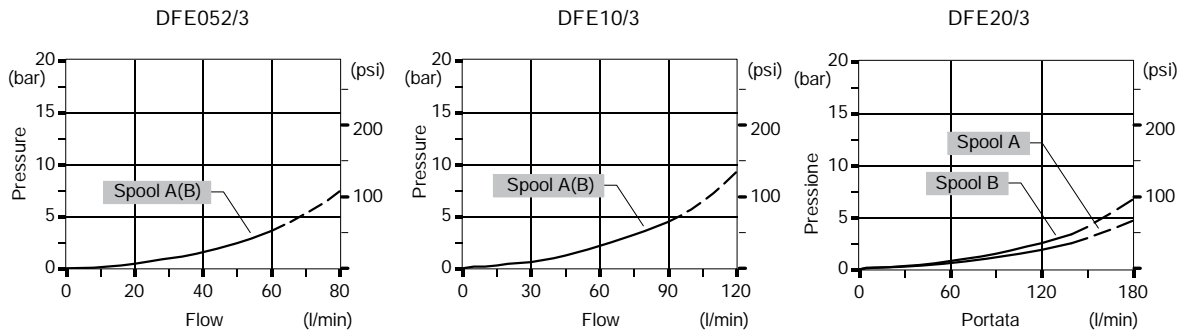

Minimum dynamic conditions: (supply = Vn-10%, coil at 70 °C)

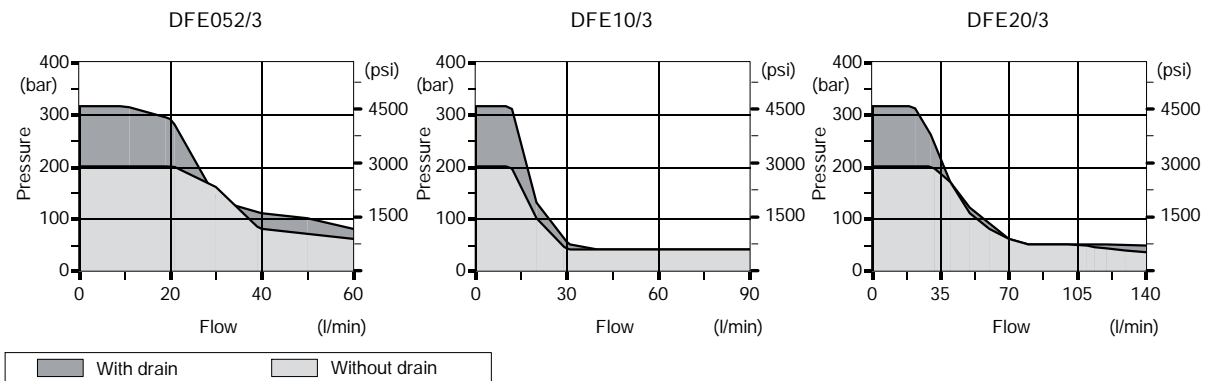

with solenoid control

DFE

Hydraulic circuit

6-way

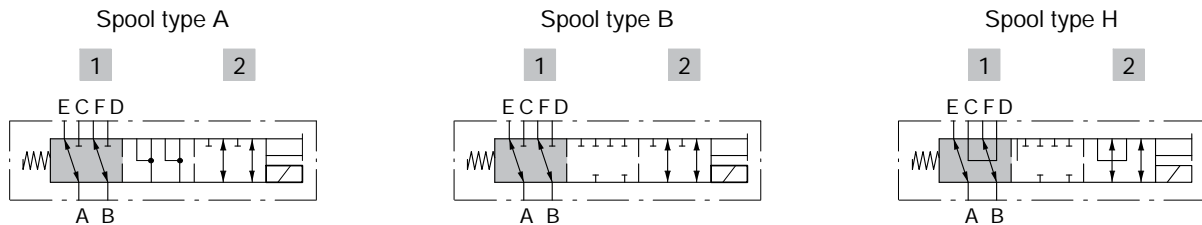
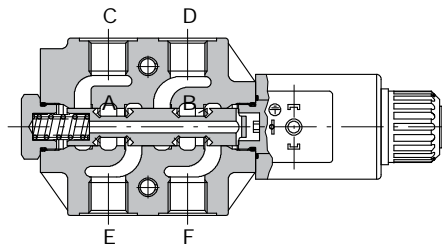

Performance data

Pressure drop versus flow: A→E(C).

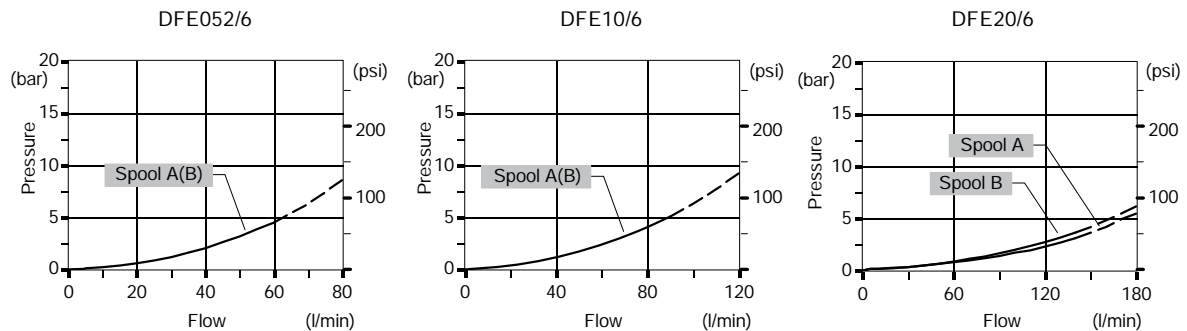

Minimum dynamic conditions: (supply = Vn-10%, coil at 70 °C)

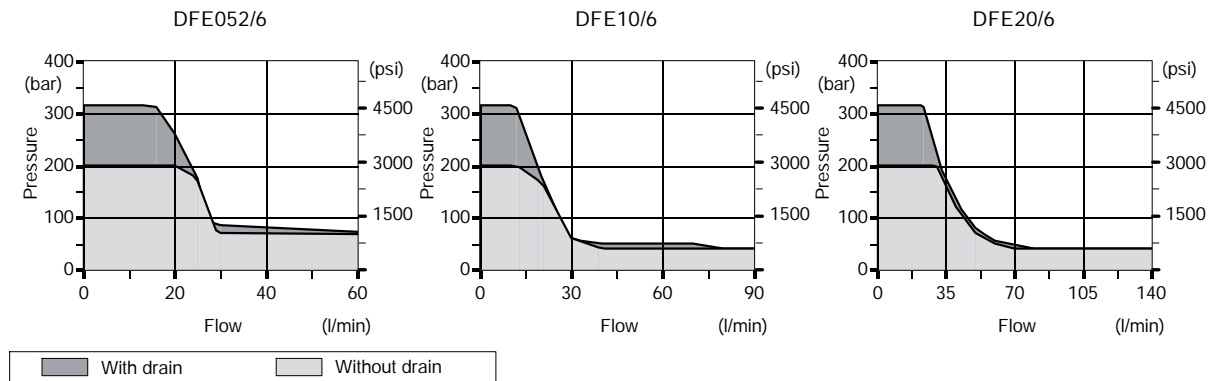

254-010

DFE

with solenoid control

Hydraulic circuit

8-way

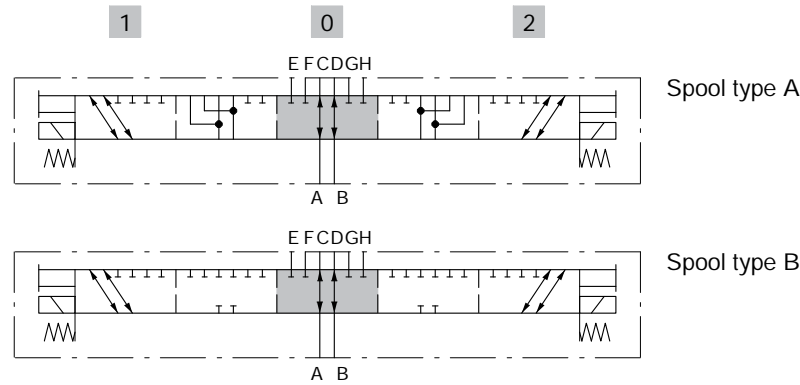
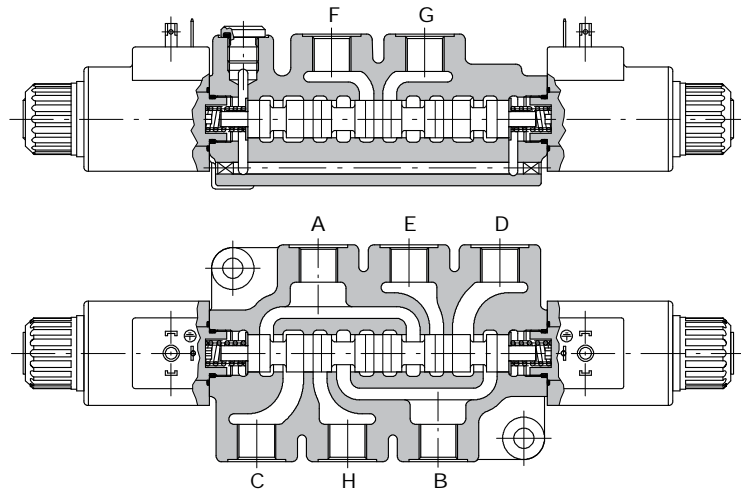

Performance data

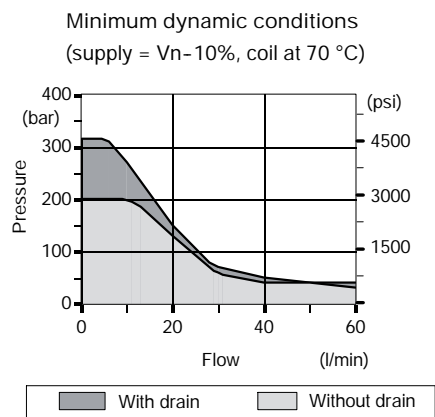
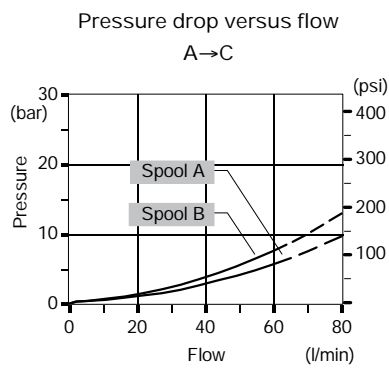

DFE052

with solenoid control

Dimensional data

6-way DFE052/6 valve

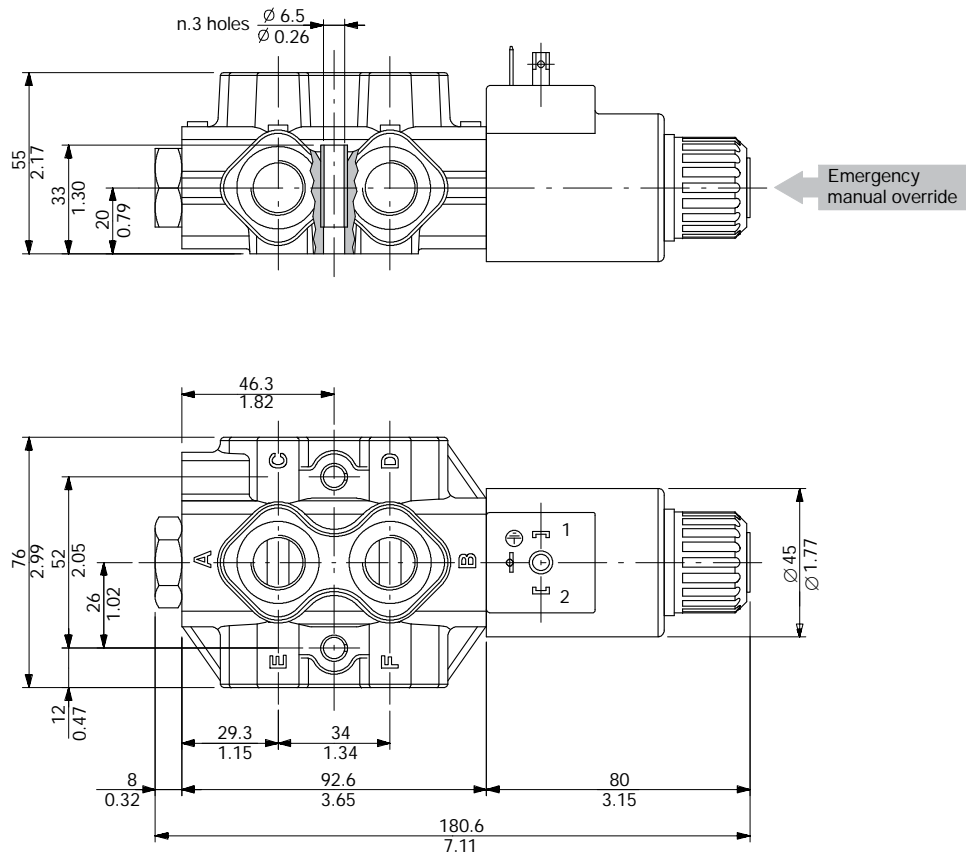

254-010

DFE052

with solenoid control

Ordering codes

Description example :

Diverter valve DFE052/2 A 18 ES - W 201-12VDC - <CVN>



Valve is supplied painted as standard, with one coat of Primer black antirust paint

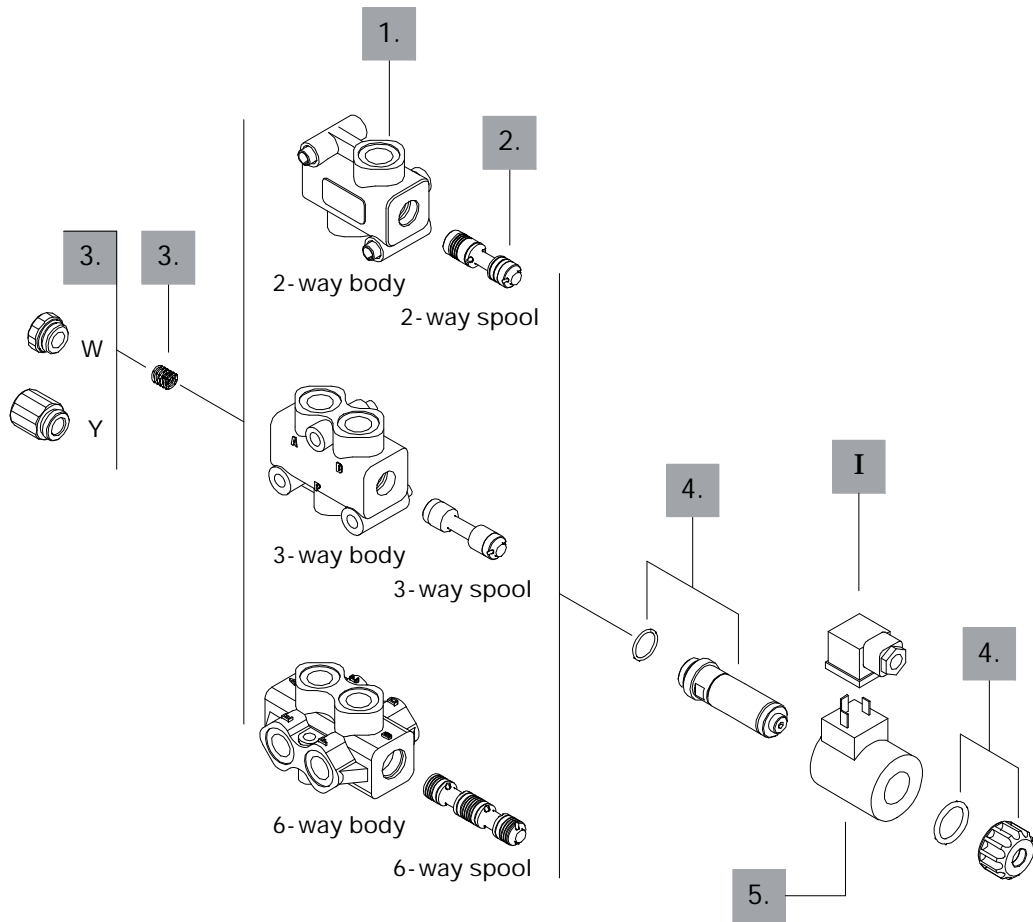

with solenoid control

DFE052

Ordering codes

2-way

1. Body *

TYPE	CODE	DESCRIPTION
DFE052/2	3CO2220321	Standard body, BSP threaded

2. Spool options

TYPE	CODE	DESCRIPTION
A	3CAS105245	2 positions with open centre in neutral
B	3CAS105145	2 positions with closed centre in neutral

3-way

1. Body *

TYPE	CODE	DESCRIPTION
DFE052/3	3CO2220321	Standard body, BSP threaded

2. Spool options

TYPE	CODE	DESCRIPTION
A	3CAS105245	3-way, 2 positions with ports connected in transit position
B	3CAS105145	3-way, 2 positions with ports closed in transit position
D	3CAS105546	3-way, 2 positions, without transit position, with ports closed in rest position

6-way

1. Body *

TYPE	CODE	DESCRIPTION
DFE052/6	3CO2222326	Standard body, BSP threaded

2. Spool options

TYPE	CODE	DESCRIPTION
A	3CAS105645	6-way, 2 positions with ports connected in transit position
B	3CAS105746	6-way, 2 positions with ports closed in transit position
H	3CAS105845	6-way, 2 positions, D↔C in position 1, F↔E in position 2, ports closed in transit position

3. Positioner kits page 59

TYPE	CODE	DESCRIPTION
18...W	5TAP001	Spring return in position 1
18...Y	5GIU001 *	Spring return in position 1, with G1/4 drain port

4. Tube assembly page 60

TYPE	CODE	DESCRIPTION
ES	5SOL515000	Spring return in position 1 (without coil)

5. Coil options page 60

TYPE	CODE	DESCRIPTION
101	-	Without coil (only with tube kit)
201-12VDC	4SOL515012	Without coil (only with tube kit)
201-24VDC	4SOL515024	Coil with 24VDC nominal voltage
221-12VDC	4SOL515010	Coil with 12VDC nominal voltage and "AMP Junior Timer" connection
231-12VDC	4SOL515011	Coil with 12VDC nominal voltage and "DEUTSCH DT06-2S" connection

I Optional connectors page 80

TYPE	CODE	DESCRIPTION
C02	2X1001010	According to ISO4400
C08	5CON003	Type AMP "Junior-Power-Timer"
C09	5CON130020	Type DEUTSCH "DT04-2P"

DFE052

with solenoid control

Ordering codes

Description example :

Diverter valve DFE052/8 B 8 ES3 - W 201-12VDC - <CVN>

1. 2. 3. 4. 5. 6. Valve is supplied painted as standard, with one coat of Primer black antirust paint

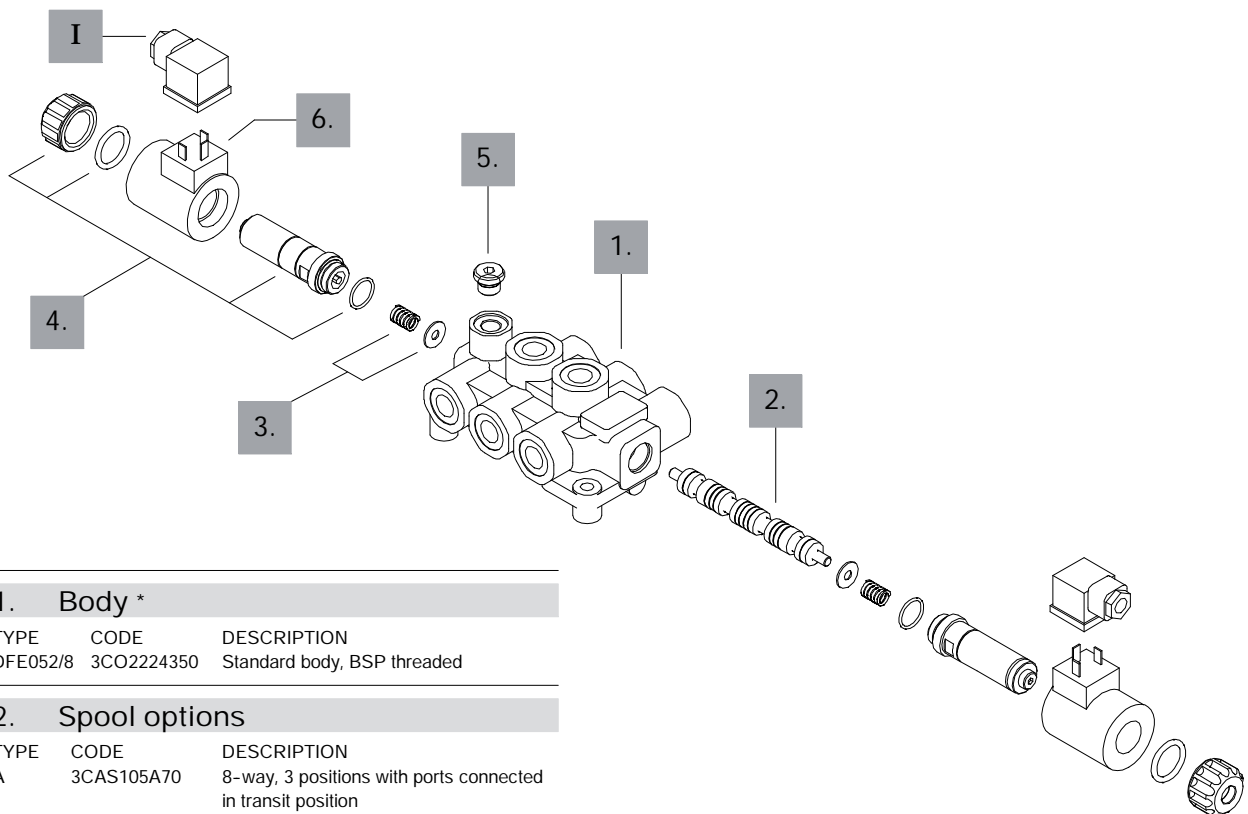

1. Body *

TYPE	CODE	DESCRIPTION
DFE052/8	3CO2224350	Standard body, BSP threaded

2. Spool options

TYPE	CODE	DESCRIPTION
A	3CAS105A70	8-way, 3 positions with ports connected in transit position
B	3CAS105B70	8-way, 3 positions with ports closed in transit position

3. Positioner kit page 59

TYPE	CODE	DESCRIPTION
8	5V08001	Spring return in neutral position

4. Tube assembly page 60

TYPE	CODE	DESCRIPTION
ES3	5SOL515000	With spring return in neutral position (without coil)

5. Drain options * page 59

TYPE	CODE	DESCRIPTION
W	3XTAP719150	With drain plugged
Y	-	With G 1/4 drain port

6. Coil options page 60

TIPO	CODICE	DESCRIZIONE
101	-	Without coil (only with tube kit)
201-12VDC	4SOL515012	Without coil (only with tube kit)
201-24VDC	4SOL515024	Coil with 24VDC nominal voltage
221-12VDC	4SOL515010	Coil with 12VDC nominal voltage and "AMP Junior Timer" connection
231-12VDC	4SOL515011	Coil with 12VDC nominal voltage and "DEUTSCH DT06-2S" connection

I Optional connectors page 80

TYPE	CODE	DESCRIPTION
C02	2X1001010	According to ISO4400
C08	5CON003	Type AMP "Junior-Power-Timer"
C09	5CON130020	Type DEUTSCH "DT04-2P"

with solenoid control

DFE052

Positioner kits

DFE052/2 - /3 - /6

18W kit

Spring return in position 1 with plug.

18Y kit

Spring return in position 1, with G1/4 joint for drain.

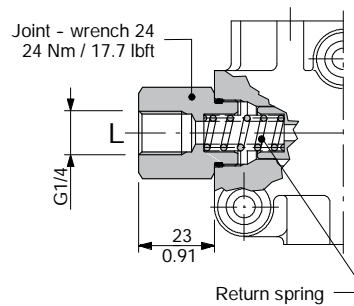
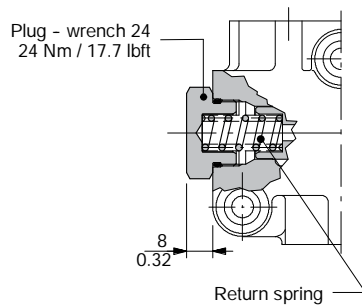

DFE052/8

8 kit

Spring return in position 0.

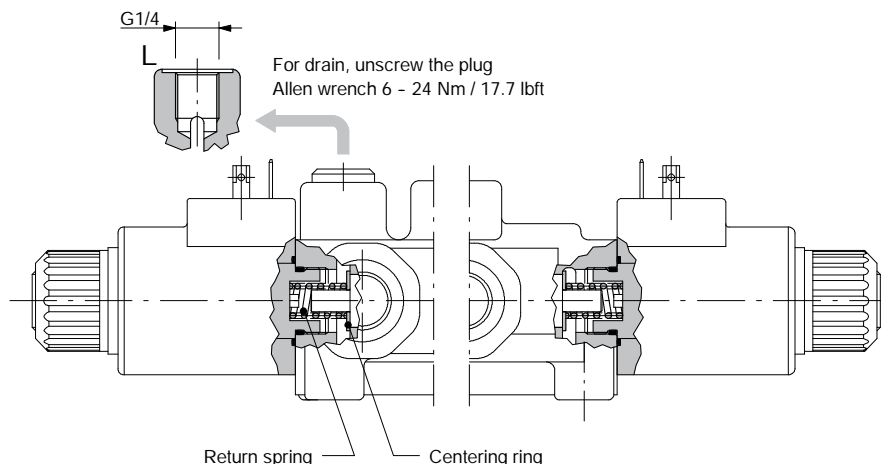
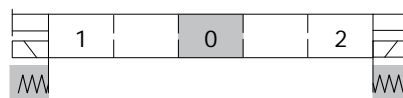

254-010

DFE052

with solenoid control

Solenoid parts

ES tube assembly

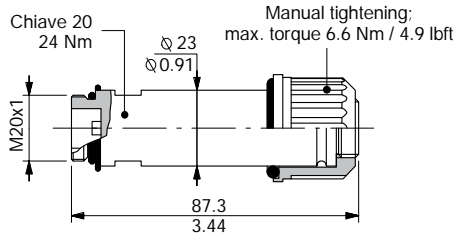

Operating features

Plunger stroke : 7.1 mm / 0.28 in

Coil options

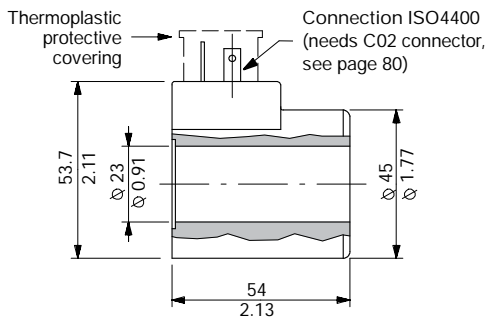

Operating features

Nominal voltage : 12VDC / 24VDC
Nominal voltage tolerance . . . : $\pm 10\%$
Power rating : 38 W
Duty cycle : 100%
Weather protection : IP66
Coil insulation : Class H

Optional coil with connector type
AMP "Junior Timer"

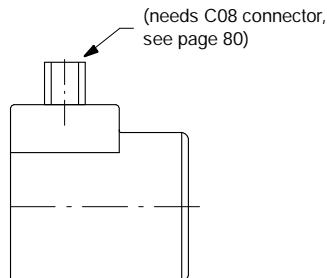

Optional coil with connector type
DEUTSCH "DT06-2S"

